



Non-Contact Interlock/Position Switch

181 GuardSwitch

Applications

- Requiring Conduit Connection
- Non-wash Down Environment
- Heavy-duty Housing

General Specifications

Enclosure	Coated aluminum
Temperature Range	-40°F to 180°F (-40°C to 80°C)
Environmental	Hermetically Sealed Contact Switch Encapsulated in Polyurethane
NEMA Rating	1, 2, 5
Protection Class	IP 64
Response Time	1 msec; 10 msec (150VA)
Life Cycles	100,000 Under Full Load; Up to 200,000,000 Under Dry Circuit
Conduit Connection	1/2" Threaded NPT

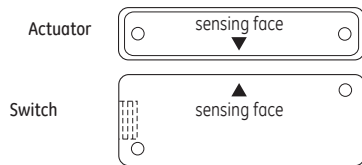
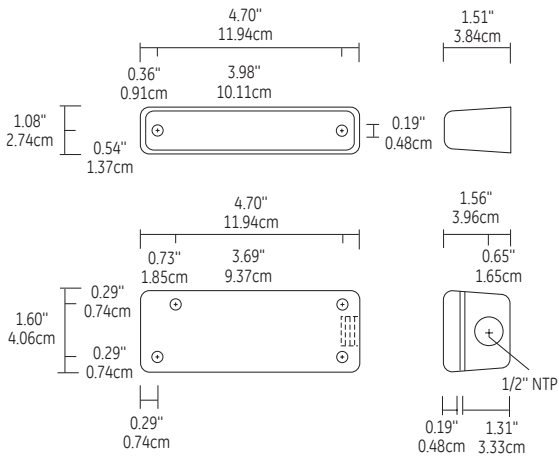

INTERLOCK SWITCH
100 SERIES

Order Information		Electrical Specifications								
Part Number	Contact ¹ Config.	Load Rating AC DC	Switching Voltage, Max. AC DC	Switching Current, Max. AC DC	Contact Resistance	Sense Range ² Nominal	Break Range Nominal	Terminal Type		
181-7Z	N.O.	100VA 84W	120V(@0.8A) 28V(@3.0A)	3.0A (@34V) ³ 3.0A (@28V) ³	1.0 Ohms	1.4" (3.5cm)	1.8" (4.6cm)	#6 Screw		

Warning— Each electrical rating is an individual maximum and cannot be exceeded!

¹ Configuration with actuator away from the switch

² Proximity of ferrous materials usually reduces sense range — typically by 50%. The shape and type of material cause a wide diversity of effects. Testing is required to determine actual sense range for specific applications.z

